

# *OWNER'S MANUAL*



**THE IGBT SERIES OF MIG/MAG  
BLUE DEMON BLUEARC 140MSI**

# CONTENTS

- 1.Safety.....	3
- 2.General Description.....	4
-3.Main Parameter.....	6
- 4.Structure of welder.....	7
- 5.Installation .....	9
- 6.Welding settings quick reference chart.....	12
- 7.Range of welding current and voltage in CO2 welding.....	17
- 8.Welding parameters table.....	18
- 9.Caution.....	20
- 10. Maintenance.....	21
- 11. Daily checking.....	22
- 12. Connection diagram of the machine.....	25
- 13. Explosion drawing.....	26
- 14. IGBT Equipment Warranty.....	27

This welding machine for industrial and professional use is in conformity with IEC974 International Safety Standard.

We hereby state that we provide one year of warranty for this welding machine since the date of purchase. See full warranty disclaimer on last page of user manual.

Please read and understand this instruction manual carefully before the installation and operation of this machine.

The contents of this manual may be revised without prior notice. For most current version of manual visit [www.bluedemonwelding.com](http://www.bluedemonwelding.com)

This instruction manual is issued in June 2020.

## 1.SAFETY

Welding and cutting is dangerous to the operator, people in or near the working area, and the surroundings if the machine is not correctly operated. Therefore, the performance of welding/cutting must only be under the strict and comprehensive observance of all relevant safety regulations. Please read and understand this instruction manual carefully before installation and operation.

- Do not switch function modes while machine is in use. This will damage machine and void warranty.
- Disconnect and remove the electrode-holder cable when not in MMA (SMAW) mode.
- A safety switch is necessary to prevent the machine from electric leakage.
- Use only welding tools and consumables of high quality.
- Operators should be qualified.

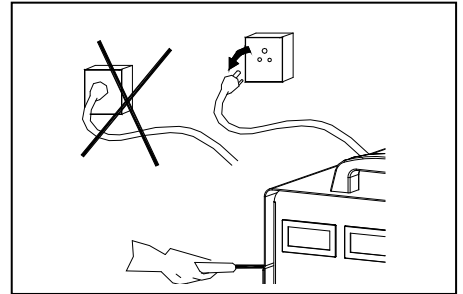

### Electric shock: It can be fatal!

- Connect the earth cable according to standard and local regulation.
- Avoid all contact with live electrical parts of the welding circuit, electrodes and wires with bare hands. It is necessary for the operator to wear dry welding gloves while he/she performs the welding task.
- The operator should keep the working piece insulated from himself/herself.



### Smoke and gas generated while welding or cutting can be harmful to people's health.

- Avoid breathing the smoke and gas generated while welding or cutting.
- Use fume extraction equipment if available.
- Keep the working area well ventilated.

### Arc rays: harmful to people's eyes and skin.

- Wear welding helmet, anti-radiation glass and work clothes while the welding operation is performed.
- Measures also should be taken to protect people in or near the working area.

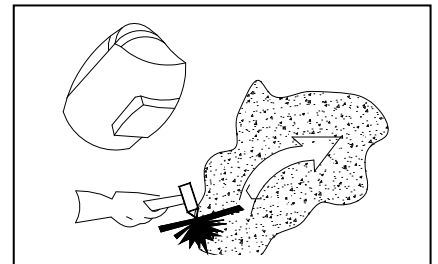

### Fire hazard

- The welding spatter may cause fire, thus remove flammable material from the work area.
- Have a fire extinguisher nearby and have a trained person ready to use it.

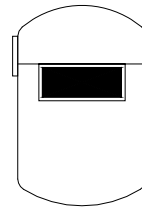

### Noise: possibly harmful to peoples' hearing.

- Noise is generated while welding/cutting, wear approved ear protection if noise level is too high.

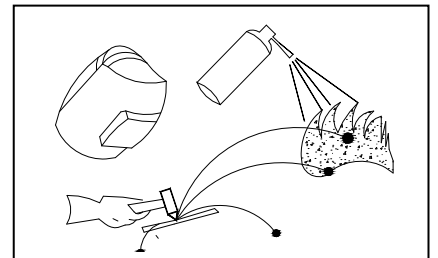

### Machine fault:

- Consult this instruction manual.
- Contact your local dealer or supplier for further advice.

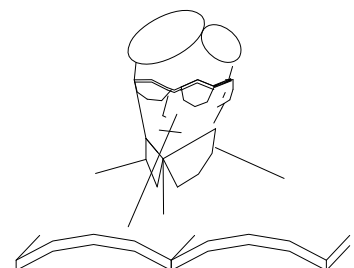

## 2.GENERAL DESCRIPTION

This welding machine is composed of an inverter MIG welder power supply with invariable voltage output external characteristics manufactured with advanced IGBT inverter technology designed by the manufacturer.

With high-power component IGBT, the inverter converts the DC voltage, which is rectified from input 50Hz/60Hz AC voltage, to high frequency 20KHz AC voltage; consequently, the voltage is transformed and rectified. The features of this machine are as follows:

- IGBT inverter technology, current control, high quality, stable performance.
- Closed feedback circuit, invariable voltage output, great ability of balance voltage up to  $\pm 15\%$ ;
- Electron reactor control, stable welding arc, minimal spatter, deep molten pool, excellent weld bead profile.
- Welding voltage can be preset, and the voltmeter displays the preset voltage value when not welding.
- Both welding current and welding voltage can be observed at the same time.
- Burn back time is adjustable.
- Slow wire feeding during arc starting. Reliable arc starting.
- Wire feeding is separate from the welding machine providing a wider welding operation range.
- Small-sized, light-weight, easy to operate, and economical.

### Unpacking your machine

When unpacking inspect carefully for any damage that may have occurred during transit. Check carefully to ensure all the contents on the list below have been received in good condition

Included items:

No.	Description	Qty.	Pic
1	MIG Welder	1set	
2	Operator's Manual	1pc	
3	Electrode Holder	1pc	
4	Earth Clamp	1pc	

### Operating environment

Adequate ventilation is required to provide proper cooling for the BLUEARC 140MSI. Ensure that the machine is placed on a stable level surface where clean cool air can easily flow through the unit. The BLUEARC 140MSI has electrical components and control circuit boards which will be damaged by excessive dust and dirt, so a clean operating environment is essential.

## Block Diagram

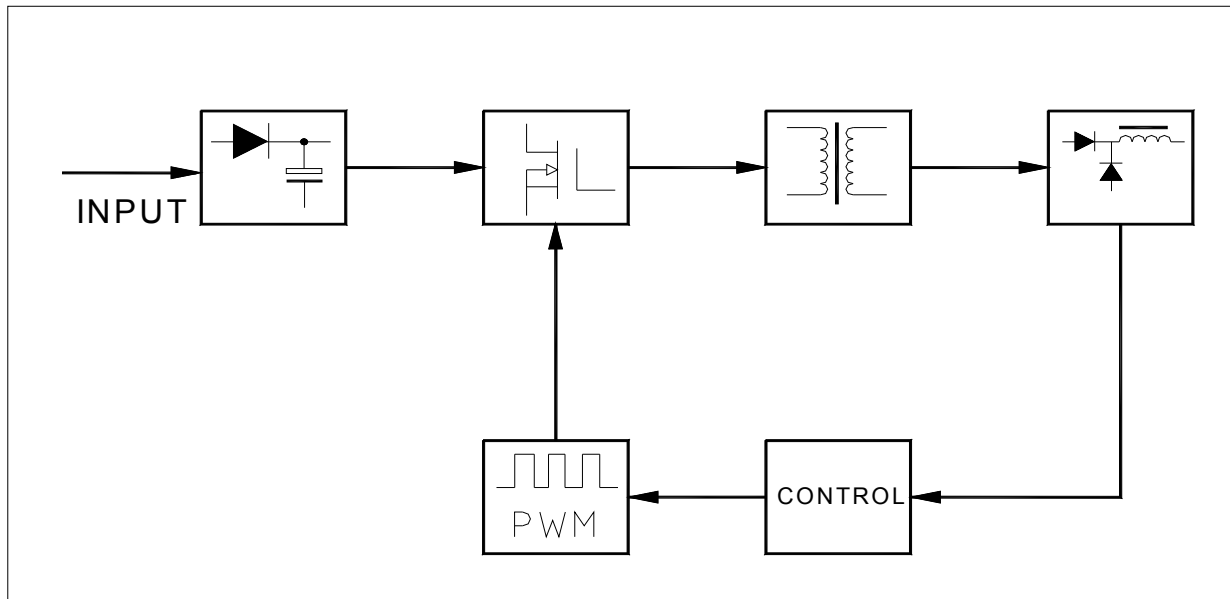

### 3. MAIN PARAMETER

#### Main Parameter

MODEL	BLUEARC-140MSI	
Power supply voltage	120±10%	
Rated input capacity	6	
Frequency(inverter)	45	
Rated input current	45\24.6	
Output current range	50-140	10-120
Function	MIG	MMA
Duty cycle (40°C 10min)	30% 140A	30% 120A
	60% 108A	60% 92A
	100% 76A	100%65A
No load voltage	51	
Efficiency	80	
Power factor	0.75	
IP	21S	
Insulation class	H	
Cooling way	FAN & AIR	
Dimension	430x150x290	
Wire diameter	.023"-.035"	1/16"-3/32"
Electrode type	Fe & Al	6013,7018,etc.
Net weight	10	

Note : The welding duty cycle is the percentage of actual continuous welding time that can occur in a ten minute cycle. For example: 15% at 200amps- this means the welder can weld continuously at 200 amps for 1.5 minutes and then the unit will need to be rested for 8.5 minutes.

The duty cycle can be affected by the environment in which the welder is used. In areas with temperatures exceeding 40°C, the duty cycle will be less than stated. In areas less than 40 °C, higher duty cycles have been obtained

All tests on duty cycles have been carried out at 40°C with a 50%. So in practical working conditions the duty cycles will be much greater than those stated above.

#### 4. Structure of welder



1. Current adjustment
2. Voltage adjustment
3. Over temperature protection LED
4. Welding mode switch
5. Integrated MIG torch
6. Positive (+) Welding Output Terminal
7. Negative (-) Welding Output Terminal

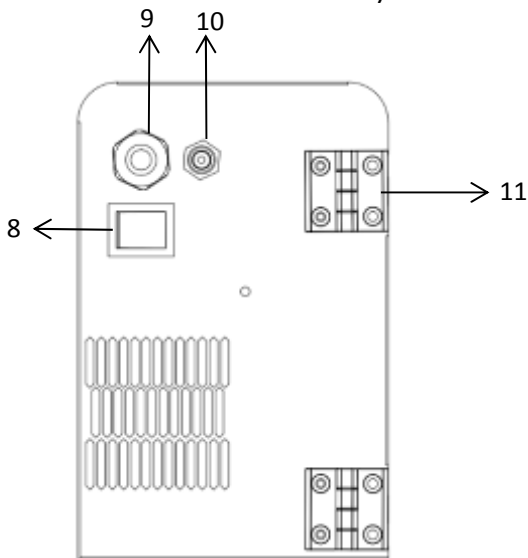

8. Power switch
9. Power cable
10. Welding gas inlet
11. Hinge



12. MIG wire drive roller
13. MIG wire feeder
14. MIG wire spool shaft

14

13

12





15

- 15. Electrode holder
- 16. Alligator clip (ground clamp)



16

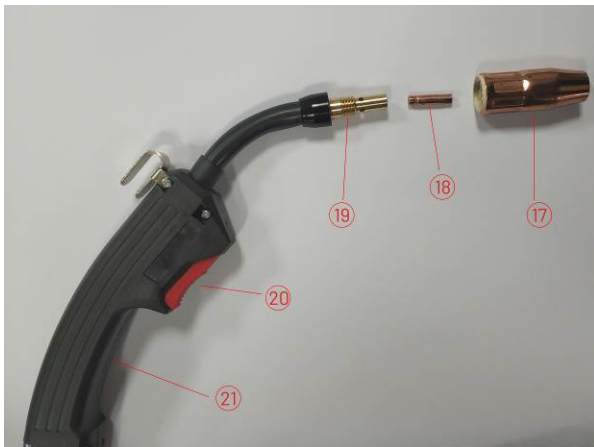

- 17. Nozzle
- 18. Contact Tip
- 19. Tip Adapter
- 20. Trigger
- 21. Handle

## 5.INSTALLTION

### 5.1. MIG Welding Set Up & Operation

#### 5.1.1 Fitting the spool

5.1.1.1 open the cover door for the wire feed compartment. Remove the wire spool retainer(14) by threading off counter-clockwise.

5.1.1.2 fit either a 4in or 8in diameter wire spool to the spool holder, ensuring the end of the wires exits towards the wire feeder from the bottom of the spool. Refit the wire spool retainer(14) and finger tighten.

5.1.1.3 set the spool brake tension by rotating the adjustment screw(14) using an Allen wrench. Clockwise to increase brake tension, counter-clockwise to decrease brake tension. The spool brake tension should be set so that the spool can rotate freely, but does not continue to rotate once the wire feed stops. This may need to be adjusted as the wire is used up and the spool weight decreases.

#### 5.1.2 Loading wire feeder

5.1.2.1 release the wire feeder tension arm (shown below) by pivoting the wire feed tension adjuster(13) as pictured below



5.1.2.2 check the wire drive roller (12) groove matches the selected MIG wire type and size. The drive roller will have two different sized grooves, the size of the groove in use is stamped on the side of the drive roller. For flux cored 'soft' wire ,such as that used in gasless MIG welding, the drive roller groove is knurled. For solid 'hard' MIG wire, the roller groove has a 'v' shaped profile.

5.1.2.3 the drive roller(12) is removed by threading the drive roller retainer off in the counter-clockwise direction. Once the correct drive roller profile is selected, re-fit the drive roller.

5.1.2.4 thread the MIG wire from the spool through the input guide tube, through the roller groove and into the outlet guide tube

5.1.2.5 Replace the tension arm and the tension adjustment. Double check the wire has located correctly in the drive roller groove.

5.1.2.6 Adjusting wire feed tension: this is accomplished by winding the knob on the wire tension adjustment arm. Clockwise will increase tension, counter-clockwise will decrease tension. There is a numbered scale on the tensioner to indicate the position. Ideal tension should be as little as possible, while maintaining a consistent wire feed with no drive roll slippage. Check all other possible causes of slippage, such as; incorrect/ worn drive roller, worn/ damaged torch consumables, blocked/ damaged torch feed liner, before increasing feed tension.

**Warning!** - Before changing the feed roller or wire spool, ensure that the mains power is switched off

**Warning!** - The use of excessive feed tension will cause rapid and premature wear of the drive roller, the support bearing and the drive motor.

## Connection of Shield Gas

Connect inert gas hoses to gas inlet (10) with standard hose fitting and tighten securely. If using a hose without a fitting, secure with hose clamp. The supply of your inert shielding gas should include the gas tank (aka bottle), regulator, and gas hose.

Please note:

- 1) Leakage of shielding gas affects the performance of arc welding.
- 2) Avoid the sunshine on the gas cylinder to eliminate the possible explosion of gas cylinder due to the increasing pressure of gas resulted from the heat.
- 3) Do not store your gas cylinder horizontally. Always secure your gas cylinder to avoid tipping or falling over.
- 4) Ensure no person is up against the regulator, before the gas release or shut the gas output.
- 5) The gas output volume meter (regulator) should be installed vertically to ensure the precise measuring.
- 6) Before the installation of gas regulator, release and shut the gas for several time in order to remove the possible dust on the sieve to avail the gas output.

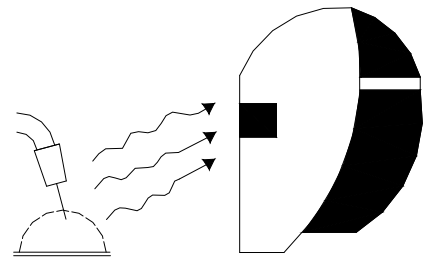
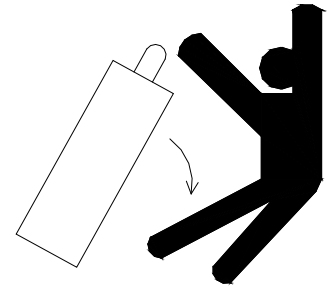
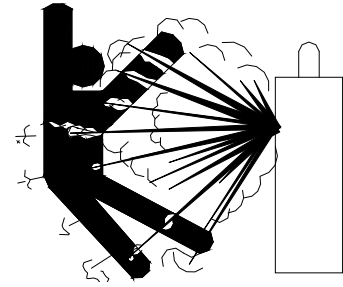

### 5.1.3 Setup for SMAW/STICK mode operation

Note - SMAW/Stick Welding requires an STICK lead set.

5.1.3.1 Connect Electrode holder Quick Connector to the positive (+) welding output terminal (6)

5.1.3.2 Connect Earth Lead Quick Connector to the negative (-) output welding terminal (7)

### 5.1.4 Controls for MIG welding

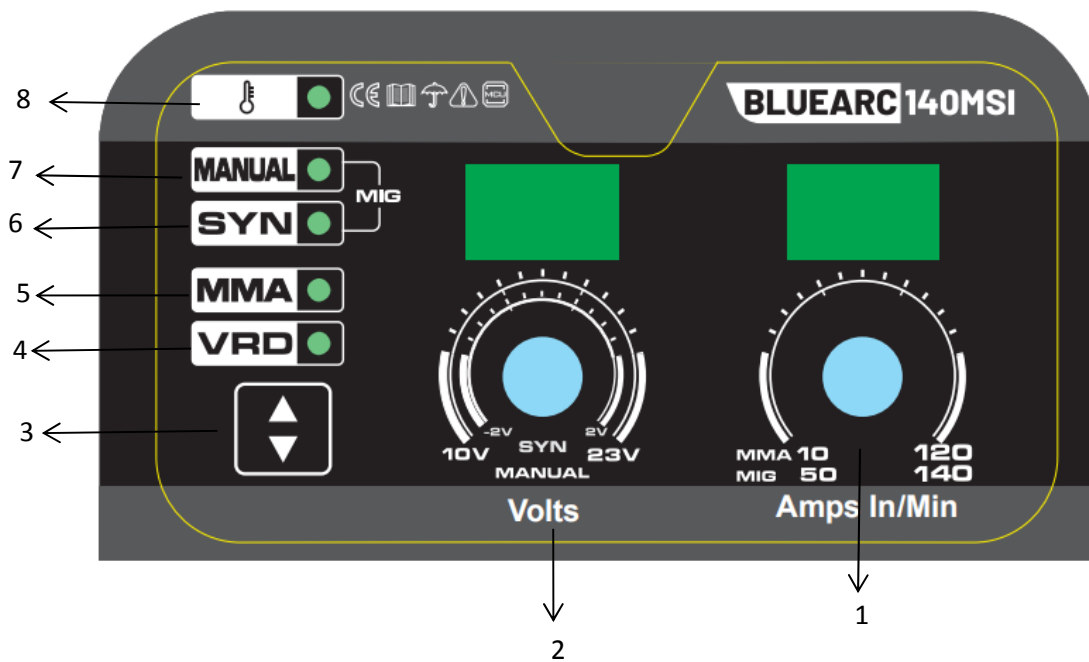

- 1 Current adjustment
- 2 Voltage adjustment
- 3 Welding mode switch
- 4 VRD = Voltage Reduction Device indicator light safety feature to reduce OCV for improper MMA connection to operator.
- 5 MMA – SMAW mode
- 6 SYN-synergize voltage and ampere automatically
- 7 MANUAL-manually adjust voltage and ampere in GMAW/FCAW mode
- 8 Temperature overload indicator light , after cooling down, machine can work again.

**Note:** this MIG welding machine MIG welding can be both synergic and separate, select the wire feed speed the voltage parameter will be matched automatically.

Please select the wire diameter according to the wire you use.

Voltage refine initialization value is 0, refine the voltage by  $\pm 1V$  according to different kinds of gas.

## 5.2 MMA Welding Set Up & Operation

### 5.2.1 MMA Introduction

- 2) MMA function is with imported IGBT and fast recovery diodes as main electric components. It is supplemented by a specially developed main PCB board. In addition, the uniform regulation of welding current has been designed to guarantee the arc reach good welding process adaptability. What's more, its perfect dynamic protection features ensure that it is safe and reliable when use. It is ideal for using low carbon steel, stainless steel, alloy steel etc.

### 5.2.2 MMA Features:

- 30% high duty cycle.
- Lower cost operation, more portable, more compact, superior output.
- Excellent arc properties and solution droplet transfer.
- With the protections of over-heating, over-voltage, over-current.
- Digital display function when use (only for plastic shell).
- Plastic handle makes it easy to carry.
- Convenient quick connection for the output makes it quick, safe, simple and stable.

### 5.2.3 Operation control and connectors.

- (1) Negative (-) Output terminal. FOR MMA welding Plug Earth Lead into this Terminal. FOR TIG Welding Plug TIG Torch into this terminal.
- (2) Positive (+) Output terminal . For MMA welding plug Arc Lead into this terminal. For TIG Welding plug Earth Lead into this terminal.
- (3) Mode Selector Button (MMA,MMA VRD, TIG).
- (4) Current digital display
- (5) Thermal overload light. This is illuminated if the machine overheats
- (6) Amperage adjustment knob
- (7) VRD Warning light.
- (8) Power Access client: Primary power Lead.
- (9) On/Off Switch



### 5.2.4 Installation & Adjustment

Note: Please follow steps in strictly accordance with installation! Turn Off power at Mains power point!

The equipment protection level is IP21s. Do not use it in the rain!

### 5.2.5 Installation

- (1) Connect machine to power outlet.
- (2) Ensure Power Point is in good condition.
- (3) With a multi meter measure the input voltage is within the fluctuation range.
- (4) Ensure Ground Cable is fitted securely to the front panel.
- (5) Ensure Electrode lead is fitted securely to front panel.
- (6) Ensure Earth is well attached and grounded to the job.

Operator also on the base metal and welding rod to choose DCSP method. In general, the basic electrode reverse method is recommended (ie, connected to the positive electrode).

### 5.2.6 Operation

- (1) To operate the machine, turn the power switch, so that the power switch is in the “ON” position, then the power indicator light & fan comes on, the device is ready to use.
- (2) Please note, choose correct polarity selection based on the electrodes to be used.
- (3) Ensure Welding leads are kept in good condition, damaged leads or earth clamp can affect weld performance.

## **5.3 Safety**

### **5.3.1 Self-Protection**

- \* The user must comply with occupational safety and health rules and wear appropriate labor protective equipment. Try to avoid injury on eye and skin.
- \* It is safe to cover your head with face mask while welding, only do the observation on the arc through the window of the mask.
- \* Don't expose any part of the body at the same time to the welding positive and negative output terminals without insulated protection.

### **5.3.2 Cautions**

- \* While replacing or modulating, the strength should not be too much in order to avoid causing damage to the device.
- \* Check the connection to see if it is correct or reliable each time before working. Besides, ensure the grounding outlet device correct.
- \* While using, as smoke is harmful to human's health, the operation must be carried out in the ventilation and exhaust facilities.
- \* Prohibit non-professionals to change or replace the welder.
- \* Since the welder owns strong electromagnetic and radio frequencies, the people with cardiac pacemakers affected by the interference electromagnetic, electrical frequency are not allowed to stay nearby.
- \* When it works, please pay attention to its rated duty cycle. Do not overload.

### **5.3.3 Safety Precaution for Installation and Location**

- \* In some areas, where something may fall from the sky, personal safety precaution should be taken.
- \* In some areas around construction site, something like the dust, acid, corrosive gases or other substance in the air can not exceed the standard value except those generated while welding.
- \* It should be equipped in the open air where there is no direct sunlight, anti-rain, temperature range from -10°C to +40°C and low humidity place.
- \* 50cm space is needed to ensure good ventilation.
- \* No metal impurities are tolerant inside the welder.
- \* In some areas, there is no severe vibration.
- \* Make sure no interference will be caused to the surrounding in the welding area.
- \* Whether the power supply capacity is sufficient to allow the welder to work normally or not. And a safety protection device should be equipped in the input power.
- \* Prevent it from dumping if the welder is put in the place of over 10°incline.

### 5.3.4 Security Check

The following items must be checked up by the operator each time before access to the power source.

- \* Make sure the power socket is reliably grounded.
- \* Make sure the output terminals are well connected without short circuit.
- \* Make sure output and input cables are perfect with no exposure.

The welding machine must be inspected by professionals at regular time (not exceed 6 months). The contents as follow:

- \* Whether the electronic components are loosed or not and dust removal must be conducted.
- \* Whether the panel mounted on the device should be able to guarantee the normal implementation of the machine.
- \* Whether the input cables are damaged or not. If yes, safe handling must done.



#### **Warning!**

**Disconnect the power source before servicing it. Contact with the manufacturer or agent immediately to acquire the service and support skills when users do not have the ability to repair it.**

### 5.3.5 Environment

- \* Working temperature:  $-10^{\circ}\text{C}\sim 40^{\circ}\text{C}$ .
- \* Transportation and storage:  $-25^{\circ}\text{C}\sim 55^{\circ}\text{C}$ .
- \* Relative air humidity:  $40^{\circ}\text{C}\leq 50\%$ ;  $20^{\circ}\text{C}\leq 90\%$ .
- \* The dust, acids, corrosive gases and substance in the ambient air must be lower normal level except those from welding process.
- \* Altitude must be less than 1km.
- \* Keep good ventilation at a distance of 50cm around.
- \* Put it in somewhere the speed of wind not less than 1m/s.

## 6.Welding settings quick reference chart

RPWMI G1400i Welding Settings Quick Reference Chart

Welding Parameter		Material Thickness								
Welding Material	Wire Type	Polarity	Wire Size	Shielding Gas	1.0mm	2.0mm	3.0mm	4.0mm	5.0mm	6.0mm
Mild Steel	Self Shielded Flux Core	Torch Negative (-)	0.8mm	N/A	-	14.0/2.7	16.2/3.0	18.5/6.1	24.5/9.0	-
Mild Steel	Self Shielded Flux Core	Torch Negative (-)	0.9mm	N/A	-	16.3/2.0	18.8/3.6	20.2/4.1	21.0/7.5	21.6/9.0
Mild Steel	Solid Wire ER70S-6	Torch Positive (+)	0.6mm	75% Argon + 25% CO2	15.9/3.4	19.5/7.8	-	-	-	-
Mild Steel	Solid Wire ER70S-6	Torch Positive (+)	0.8mm	75% Argon + 25% CO2	12.8/2.0	14.1/3.3	17.5/6.6	20.0/8.2	21.0/9.0	21.0/9.0
Mild Steel	Solid Wire ER70S-6	Torch Positive (+)	0.6mm	100% CO2	14.2/2.1	19.8/8.1	-	-	-	-
Mild Steel	Solid Wire ER70S-6	Torch Positive (+)	0.8mm	100% CO2	13.6/2.3	14.4/3.6	18.4/4.2	21.1/8.5	22.6/9.0	-

Use this chart as a guide only, as optimal settings will vary with joint type and operator technique. Cells left blank are not a recommended configuration.



## Basic welding guide

### MIG (GMAW/FCAW) Basic Welding Technique

Two different welding processes are covered in this section (GMAW and FCAW), with the intention providing the very basic concepts in using the MIG mode of welding, where a welding gun is hand held, and the electrode (welding wire) is fed into a weld puddle, and the arc is shielded by an inert welding grade shielding gas or inert welding grade shielding gas mixture.

**GAS METAL ARC WELDING (GMAW):** This process, also known as MIG welding, CO<sub>2</sub> welding, Micro Wire Welding, short arc welding, dip transfer welding, wire welding etc., is an electric arc welding process which fuses together the parts to be welded by heating them with an arc between a solid continuous, consumable electrode and the work. Shielding is obtained from an externally supplied welding grade shielding gas or welding grade shielding gas mixture. The process is normally applied semi automatically, however the and fairly thick steels, and some non-ferrous metals in all positions.

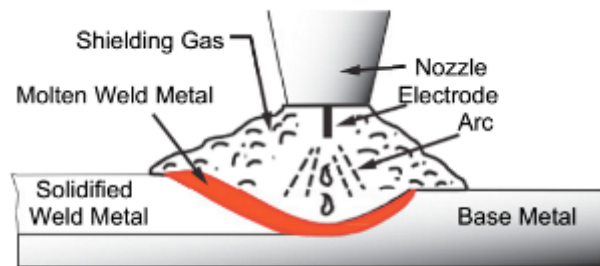

## GMAW Process

**FLUX CORED ARC WELDING (FCAW):** This is an electric arc welding process which fuses together the parts to be welded by heating them with an arc between a continuous flux filled electrode wire and the work. Shielding is obtained through decomposition of the flux within the tubular wire. Additional shielding may or may not be obtained from an externally supplied gas or gas mixture. The process is normally applied semi automatically; however the process may be applied automatically or by machine. It is commonly used to weld large diameter electrodes in the flat and horizontal position and small electrode diameters in all positions. The process is used to a lesser degree for welding stainless steel and for overlay work.

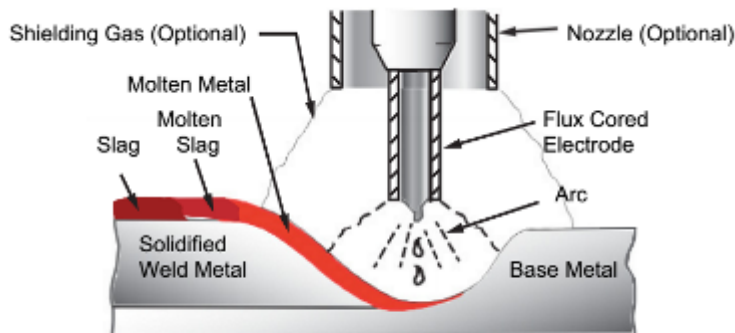

## FCAW Process

### Position of MIG Torch

The angle of MIG torch to the weld has an effect on the width of the weld

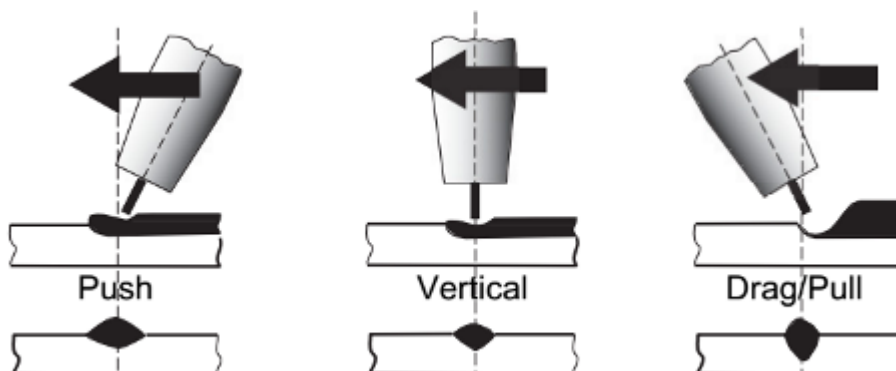

The welding gun should be held at an angle to the weld joint. (See Secondary Adjustment Variables below) Hold the gun so that the welding seam is viewed at all times. Always wear the welding helmet with proper filter lenses and use the proper safety equipment.

**CAUTION**

Do not pull the welding gun back when the arc is established. This will create excessive wire extension (stick-out) and make a very poor weld.

The electrode wire is not energized until the gun trigger switch is depressed. The wire may therefore be placed on the seam or joint prior to lowering the helmet.

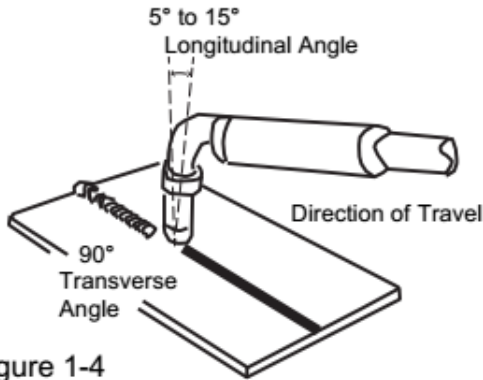

Figure 1-4

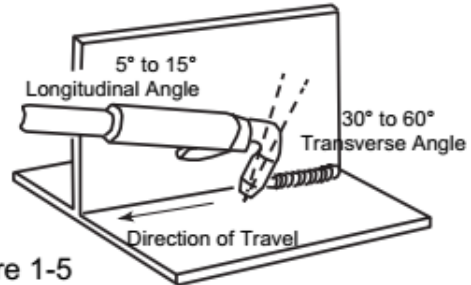
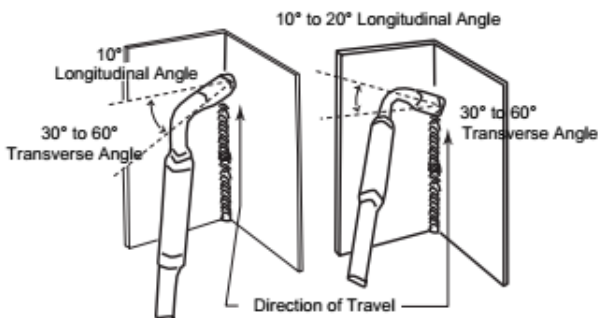

Figure 1-5



Vertical Fillet Welds  
Figure 1-6

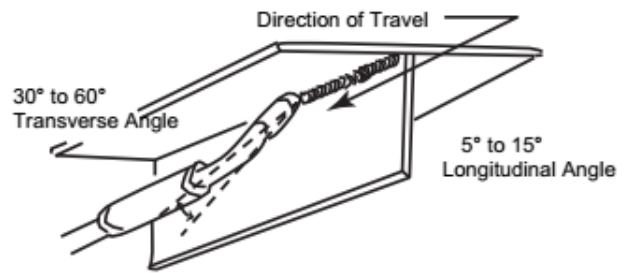

Figure 1-7

**Distance from the MIG Torch Nozzle to the Work Piece**

The electrode wire stick out from the MIG Torch nozzle should be between 10mm to 20.0mm. This distance may vary depending on the type of joint that is being welded

**Travel Speed**

The speed at which the molten pool travels influences the width of the weld and penetration of the welding run

**MIG Welding (GMAW) Variables**

Most of the welding done by all processes is on carbon steel. The items below describe the welding variables in short-arc welding of 24gauge (0.024", 0.6mm) to ¼" (6.4mm) mild sheet or plate. The applied techniques and end results in the GMAW process are controlled by these variables.

**Preselected Variables**

Preselected variables depend upon the type of material being welded, the thickness of the material, the welding position, the deposition rate and the mechanical properties. These variables are:

- Type of electrode wire
- Size of electrode wire
- Type of gas (not applicable to self-shielding wires FCAW)
- Gas flow rate (not applicable to self-shielding wires FCAW)

### Primary Adjustable Variables

These control the process after preselected variables have been found. They control the penetration, bead width, bead height, arc stability, deposition rate and weld soundness. They are:

Arc Voltage

Welding current (wire feed speed)

Travel speed

### Secondary Adjustable Variables

These variables cause changes in primary adjustable variables which in turn cause the desired change in the bead formation. They are:

1. Stick-out (distance between the end of the contact tube (tip) and the end of the electrode wire). Maintain at about 10mm stick-out

2. Wire Feed Speed. Increase in wire feed speed increases weld current, Decrease in wire feed speed decreases weld current

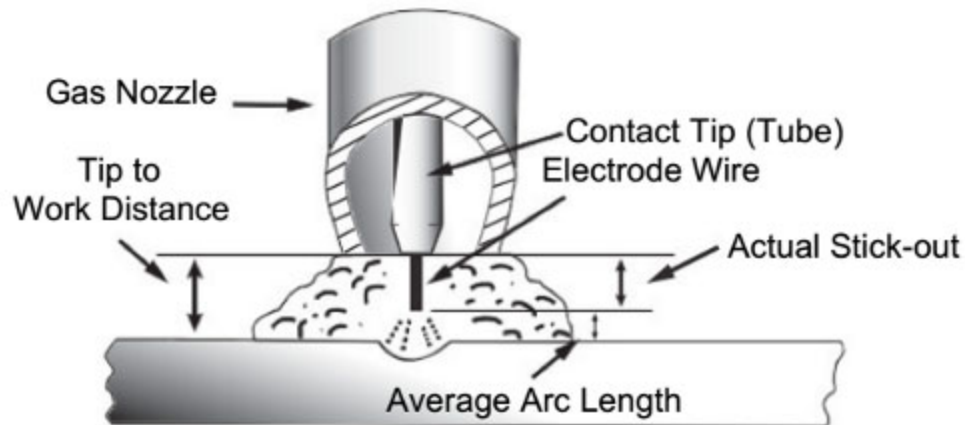

3. Nozzle Angle. This refers to the position of the welding gun in relation to the joint. The transverse angle is usually one half the included angle between plates forming the joint. The longitudinal angle is the angle between the center line of the welding gun and a line perpendicular to the axis of the weld. The longitudinal angle is generally called the Nozzle Angle and can be either trailing (pulling) or leading (pushing). Whether the operator is left handed or right handed has to be considered to realize the effects of each angle in relation to the direction of travel.

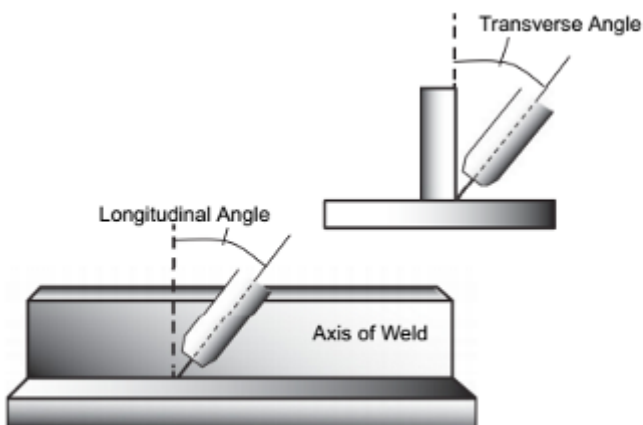

Transverse and Longitudinal Nozzle Axes

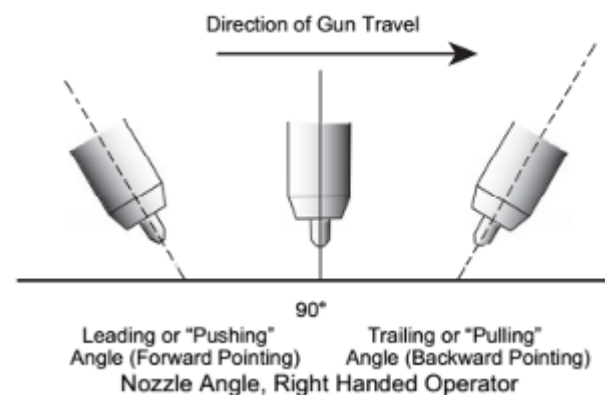

### Establishing the Arc and Making Weld Beads

Before attempting to weld on a finished piece of work, it is recommended that practice welds be made on a sample metal of the same material as that of the finished piece

The easiest welding procedure for the beginner to experiment with MIG welding is the flat position. The equipment is capable of flat, vertical and overhead positions.

For practicing MIG welding, secure some pieces of 16 or 18 gauge (0.06" 1.5mm or 0.08" 2.0mm) mild steel plate 6" x 6" (150 x 150mm). Use 0.030" (0.8mm) flux cored gasless wire or a solid wire with shielding gas

### **Setting of the Power Source**

Power source and Wire-feeder setting requires some practice by the operator, as the welding plant has two control settings that have to balance. These are the Wirespeed control and the welding Voltage Control. The welding current is determined by the Wirespeed control, the current will increase with increase Wirespeed, resulting in a shorter arc. Less wire speed will reduce the current and lengthen the arc. Increasing the welding voltage hardly alters the current level, but lengthens the arc. By decreasing voltage, a shorter arc is obtained with a little change in current level.

When changing to a different electrode wire diameter, different control settings are required. A thinner electrode wire needs more Wire-speed to achieve the same current level

A satisfactory weld cannot be obtained if the Wirespeed and Voltage settings are not adjusted to suit the electrode wire diameter and the dimensions of the work piece.

If the Wirespeed is too high for the welding voltage, "stubby" will occur as the wire dips into the molten pool and does not melt. Welding in these conditions normally produces a poor weld due to lack of fusion. If, however, the welding voltage is too high, large drops will form on the end of the wire, causing spatter. The correct setting of voltage and Wirespeed can be seen in the shape of the weld deposit and heard by a smooth regular arc sound. Refer to the Weld Guide located on the inside of the wirefeed compartment door for setup information.

### **Electrode Wire Size Selection**

The choice of Electrode wire size and shielding gas used depends on the following

- Thickness of the metal to be welded
- Capacity of the wire feed unit and Power Source
- The amount of penetration required
- The deposition rate required
- The bead profile desired
- The position of welding
- Cost of the wire

## 7. Range of welding current and voltage in CO<sub>2</sub> welding

Wireφ(in)	Short circuit transition		Granular transition	
	Current (A)	Voltage (V)	Current (A)	Voltage (V)
0.023	40~70	17~19	160~400	25~38
0.030	60~100	18~19	200~500	26~40
0.035	80~120	18~21	200~600	27~40

### -The option of the welding speed

The welding quality and productivity should be taken into consideration for the option of welding speed. In case that the welding speed increases, it weakens the protection efficiency and speeds up the cooling process. As a consequence, it is not optimal for the seaming. In the event that the speed is too slow, the work piece will be easily damaged, and the seaming is not ideal. In practical operation, the welding speed should not exceed 1m/min.

### -The length of wire stretching out

The length of wire stretching out the nozzle should be appropriate. The increase of the length of wire stretching out of the nozzle can improve the productivity, but if it is too long, excessive spatter will occur in the welding process. Generally, the length of wire stretching out the nozzle should be 10 times as the welding wire diameter.

### -The setting of the CO<sub>2</sub> flow volume

The protection efficiency is the primary consideration. Besides, inner-angle welding has better protection efficiency than external-angle welding. For the main parameter, refer to the following figure.

Option of CO<sub>2</sub> flow volume

Welding mode	Thin wire CO <sub>2</sub> welding	Thick wire CO <sub>2</sub> welding	Thick wire, big current CO <sub>2</sub> welding
CO <sub>2</sub> (L/min)	5~15	15~25	25~50

## 8. WELDING PARAMETERS TABLE

The option of the welding current and welding voltage directly influences the welding stability, welding quality and productivity. In order to obtain the good welding quality, the welding current and welding voltage should be set optimally. Generally, the setting of weld condition should be according to the welding diameter and the melting form as well as the production requirement.

The following parameter is available for reference.

### Parameter for butt-welding (Please refer to the following figure.)

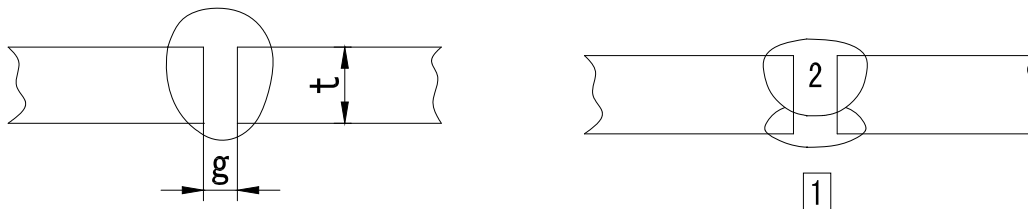

Plate thickness t (mm)	Gap g (mm)	Wire $\phi$ (mm)	Welding current (A)	Welding voltage (V)	Welding speed (cm/min)	Gas volume (L/min)
0.8	0	0.8~0.9	60~70	16~16.5	50~60	10
1.0	0	0.8~0.9	75~85	17~17.5	50~60	10~15
1.2	0	1.0	70~80	17~18	45~55	10
1.6	0	1.0	80~100	18~19	45~55	10~15
2.0	0~0.5	1.0	100~110	19~20	40~55	10~15
2.3	0.5~1.0	1.0 or 1.2	110~130	19~20	50~55	10~15
3.2	1.0~1.2	1.0 or 1.2	130~150	19~21	40~50	10~15
4.5	1.2~1.5	1.2	150~170	21~23	40~50	10~15

### Parameter for flat fillet welding (Please refer to the following figure.)

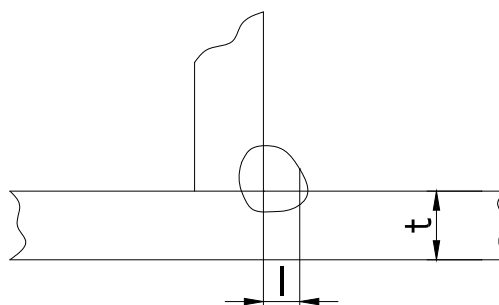

Plate thickness t (mm)	Corn size l (mm)	Wire $\phi$ (mm)	Welding current (A)	Welding voltage (V)	Welding speed (cm/min)	Gas volume (L/min)
1.0	2.5~3.0	0.8~0.9	70~80	17~18	50~60	10~15
1.2	2.5~3.0	1.0	70~100	18~19	50~60	10~15
1.6	2.5~3.0	1.0 ~ 1.2	90~120	18~20	50~60	10~15
2.0	3.0~3.5	1.0 ~ 1.2	100~130	19~20	50~60	10~20
2.3	2.5~3.0	1.0 ~ 1.2	120~140	19~21	50~60	10~20
3.2	3.0~4.0	1.0 ~ 1.2	130~170	19~21	45~55	10~20
4.5	4.0~4.5	1.2	190~230	22~24	45~55	10~20

**Parameter for fillet welding in the vertical position (Please refer to the following figure.)**

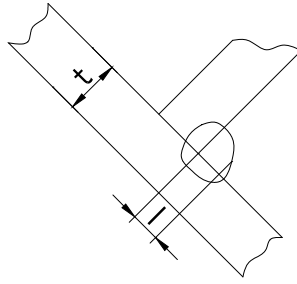

Plate thickness t (mm)	Corn size l (mm)	Wire $\phi$ (mm)	Welding current (A)	Welding voltage (V)	Welding speed (cm/min)	Gas volume (L/min)
1.2	2.5~3.0	1.0	70~100	18~19	50~60	10~15
1.6	2.5~3.0	1.0 ~ 1.2	90~120	18~20	50~60	10~15
2.0	3.0~3.5	1.0 ~ 1.2	100~130	19~20	50~60	10~20
2.3	3.0~3.5	1.0 ~ 1.2	120~140	19~21	50~60	10~20
3.2	3.0~4.0	1.0 ~ 1.2	130~170	22~22	45~55	10~20
4.5	4.0~4.5	1.2	200~250	23~26	45~55	10~20

**Parameter for Lap Welding (Please refer to the following figure.)**

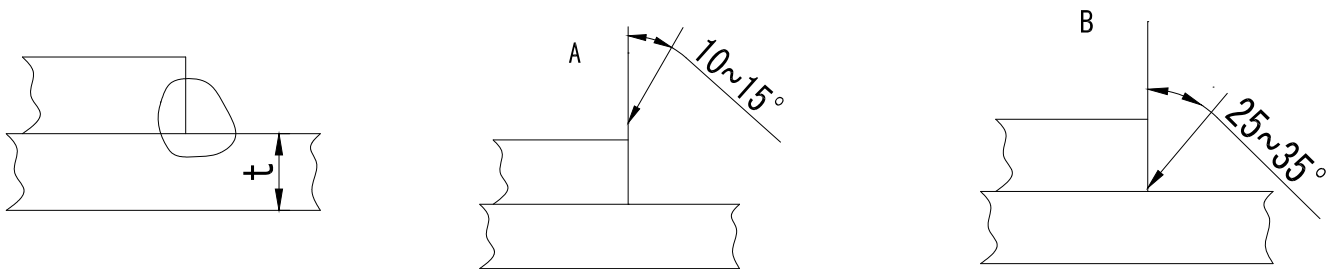

Plate thickness t (mm)	Welding position	Wire $\phi$ (mm)	Welding current (A)	Welding voltage (V)	Welding speed (cm/min)	Gas volume (L/min)
0.8	A	0.8~0.9	60~70	16~17	40~45	10~15
1.2	A	1.0	80~100	18~19	45~55	10~15
1.6	A	1.0 ~ 1.2	100~120	18~20	45~55	10~15
2.0	A or B	1.0 ~ 1.2	100~130	18~20	45~55	15~20
2.3	B	1.0 ~ 1.2	120~140	19~21	45~50	15~20
3.2	B	1.0 ~ 1.2	130~160	19~22	45~50	15~20
4.5	B	1.2	150~200	21~24	40~45	15~20

## 9.CAUTION

### 1. Working environment

- (1) Welding should be carried out in a relatively dry environment with its humidity of 90% or less.
- (2) The temperature of the working environment should be within -10°C to 40°C.
- (3) Avoid welding in the open air unless sheltered from sunlight and rain, and never let rain or water infiltrate the machine.
- (4) Avoid welding in dusty area or environment with corrosive chemical gas.
- (5) Avoid gas shielded arc welding in environment with strong airflow.

### 2. Safety tips

Over-current/overheating protection circuit is installed in this welding machine. If the output current is too high or overheating generated inside this welding machine, this welding machine will stop automatically. However, inappropriate use will still lead to machine damage, so please note:

#### 1. Ventilation

High current passes when welding is carried out, thus natural ventilation cannot satisfy the welding machine's cooling requirement. Maintain good ventilation of the louvers of this welding machine. The minimum distance between this welding machine and any other objects in or near the working area should be 30cm. Good ventilation is of critical importance for the normal performance and service life of this welding machine.

#### 2. No over-current.

Remember to observe the max load current at any moment (refer to the optioned duty cycle). Make sure that the welding current should not exceed the max load current.

If welding is carried out under a current which is higher than the max current, over-current protection will occur; the output voltage of the welding machine will be not stable; arc interruption will occur. In this case, please lower the current.

#### 3. No over-load.

Over-load current could obviously shorten the welding equipment's life, or even damage the machine.

A sudden halt may occur while the welding operation is carried out while this welding machine is of over-load status. Under this circumstance, it is unnecessary to restart this welding machine. Keep the built-in fan working to bring down the temperature inside the welding machine.

#### 4. Avoid electric shock.

An earth terminal is available for this welding equipment. Connect it with the earth cable to avoid the static and electric shock.



## 10.MAINTENANCE

1. Disconnect input plug or power before maintenance or repair on machine.
2. Be sure input ground wire is properly connect to a ground terminal.
3. Check whether the inner gas-electricity connection is well (esp. the plugs), and tighten the loose connection; if there is oxidization, remove it with sand paper and then re-connect.

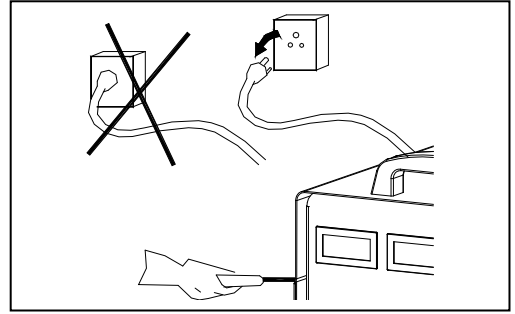

4. Keep hands, hair, loose clothing, and tools away from electrical parts such as fans, wires when the machine is switched on.

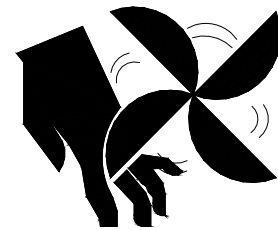

5. Clear the dust at regular intervals with clean and dry compressed air; if the working condition is with heavy smoke and air pollution, the welding machine should be cleaned daily.
6. The compressed air should be reduced to the required pressure lest the little parts in the welding machine be damaged.

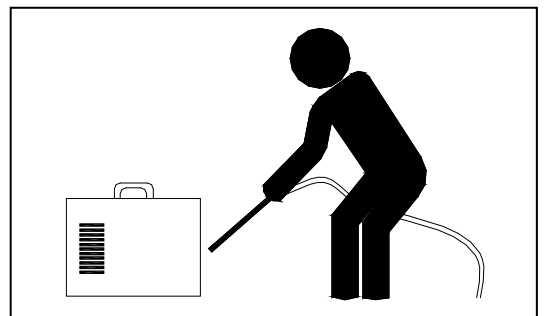

7. To avoid water and rain, if there is, dry it in time, and check the insulation with mega-meter (including that between the connection and that between the case and the connection). Only when there is no abnormal phenomenon should the welding continue.
8. If the machine is not used for a long time, put it into the original packing in dry condition.

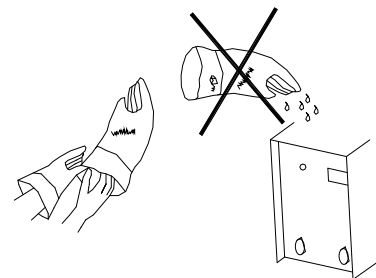

## 11.DAILY CHECKING

To make best use of the machine, daily checking is very important. During the daily checking, please check in the order of torch, wire-feeding vehicle, all kinds of PCB, the gas hole, and so on. Remove the dust or replace some parts if necessary. To maintain the purity of the machine, please use original welding parts.

**Cautions:** Only the qualified technicians are authorized to undertake the repair and check task of this welding equipment in case of machine fault.

### 11.1. Power supply

Part	Check	Remarks
Control panel	1. Operation, replacement and installation of Switch.	
	2. Switch on the power, and check if the power indicator is on.	
Fan	1. Check if the fan is functioning and the sound generated is normal.	If the fan doesn't work or the sound is abnormal, do inner check.
Power supply	1. Switch on the power supply, and check if abnormal vibration, heating of the case of this equipment, variation of colors of case or buzz presents.	
Other parts	1. Check if gas connection is available, case and other joints are in good connection.	

## 11.2. Welding torch

Part	Check	Remarks
Nozzle	1. Check if the nozzle is fixed firmly and distortion of the tip exists.	Possible gas leakage occurs due to the unfixed nozzle.
	2. Check if there is spatter sticking on the nozzle.	Spatter possibly leads to the damage of torch. Use anti-spatter to eliminate the spatter.
Contact tip	1. Check if the contact tip is fixed firmly.	Unfixed contract tip possibly leads to unstable arc.
	2. Check if the contact tip is physically complete.	The physically incomplete contact tip possibly leads to unstable arc and arc automatically terminating.
Wire feeding hose	1. Make sure that there is the agreement of wire and wire feed tube.	Disagreement of the diameters of wire and wire feed tube possibly leads to the unstable arc. Replace it/them if necessary.
	2. Make sure that there is no bending or elongation of wire feed tube.	Bending and elongation of wire feed tube possibly leads to the unstable wire feed and arc. Replace it if necessary.
	3. Make sure that there is no dust or spatter accumulated inside the wire feed tube, which makes the wire feed tub blocked.	If there is dust or spatter, remove it.
	4. Check if the wire feed tube and O-shaped seal ring are physically complete.	The Physically incomplete wire feed tube or O-shaped seal ring possibly leads to the excessive spatter. Replace the wire feed tube or O-shaped seal ring if necessary.

Part	Check	Remarks
Diffuser	1. Make sure that the diffuser of required specification is installed and is unblocked.	Defection weld or even the damage of torch occurs due to the non-installation of diffuser or the unqualified diffuser.

### 11.3. Wire feeder

Part	Check	Remarks
Pressure adjusting handle	1. Check if the pressure-adjusting handle is fixed and adjusted to the desired position.	The unfixed pressure-adjusting handle leads to the unstable welding output.
Wire-feeding hose	1. Check if there is dust or spatter inside the hose or beside wire-feeding wheel.	Remove the dust.
	2. Check if there is a diameter agreement of wire and wire-feeding hose.	Non-agreement of the diameter of wire and wire-feeding hose possibly leads to the excessive spatter and unstable arc.
	3. Check if rod and wire feeding groove are concentric.	Unstable arc possibly occurs.
Wire-feeding wheel	1. Check if there is an agreement of wire diameter and wire-feeding wheel.	Non-agreement of wire diameter and wire-feeding wheel possibly leads to the excessive spatter and unstable arc.
	2. Check if the wire groove is blocked.	Replace it if necessary.
Pressure adjusting wheel	1. Check if the pressure adjusting wheel can rotate smoothly, and it's physically complete.	Unstable rotation or physically incompleteness of the wheel possibly leads to unstable wire feeding and arc.

### 11.4. Cables

Part	Check	Remarks
Torch cable	1. Check if the cable of torch is twisted.	The twisted torch cable leads to unstable wire feeding and arc.
	2. Check if the coupling plug is in loose connection.	
Output cable	1. Check if the cable is physically complete.	Relevant measures should be taken to obtain stable weld and prevent the possible electric shock.
	2. Check if insulation damage or loose connection exists.	
Input cable	1. Check if the cable is physically complete.	
	2. Check if insulation damage or loose connection exists.	
Earth cable	1. Check if the earth cables are well fixed and not short-circuited.	Relevant measures should be taken to prevent the possible electric shock.
	2. Check if this welding equipment is well grounded.	

## 12.CONNECTION DIAGRAM OF THE MACHINE

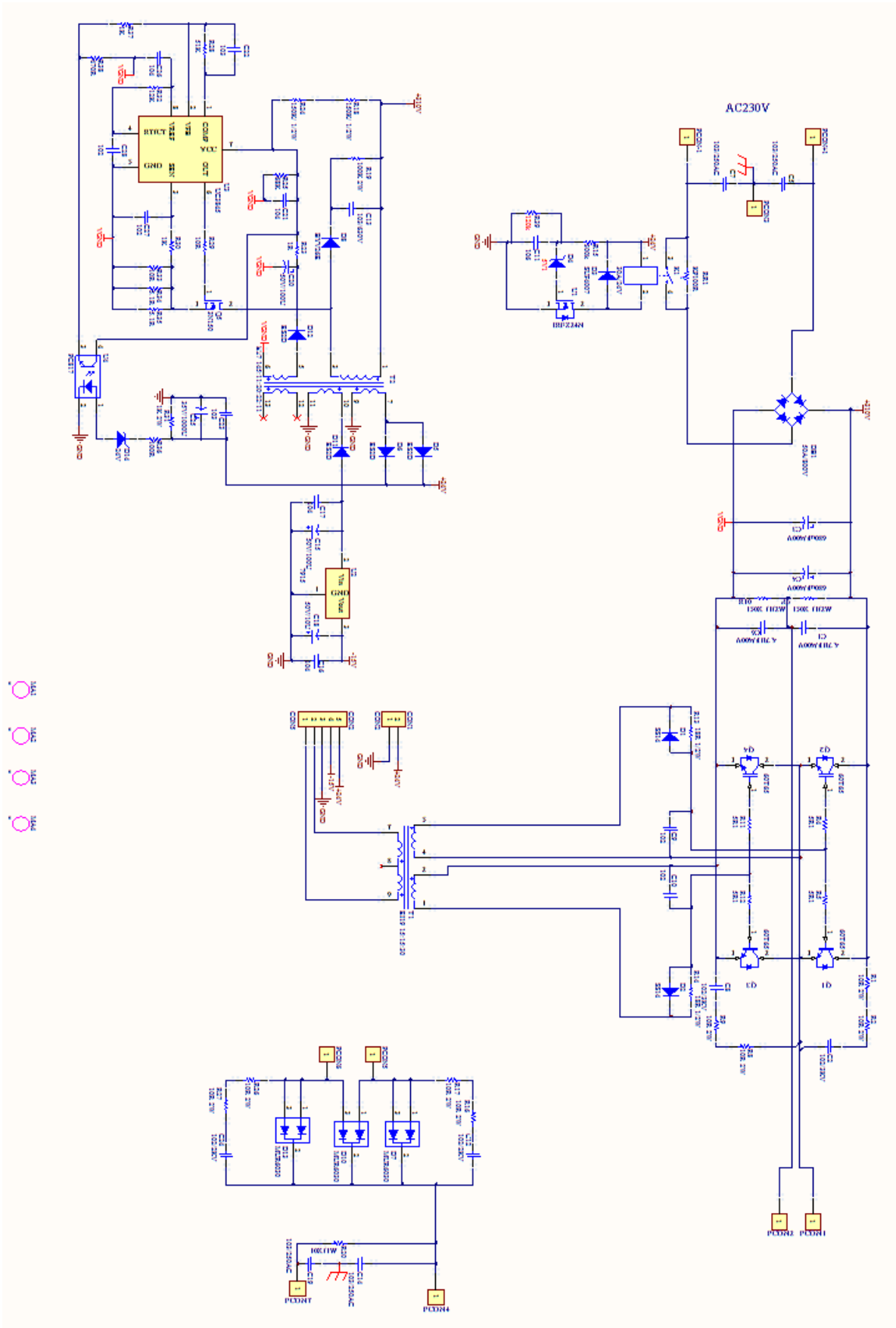

### 13.EXPLOSION DRAWING

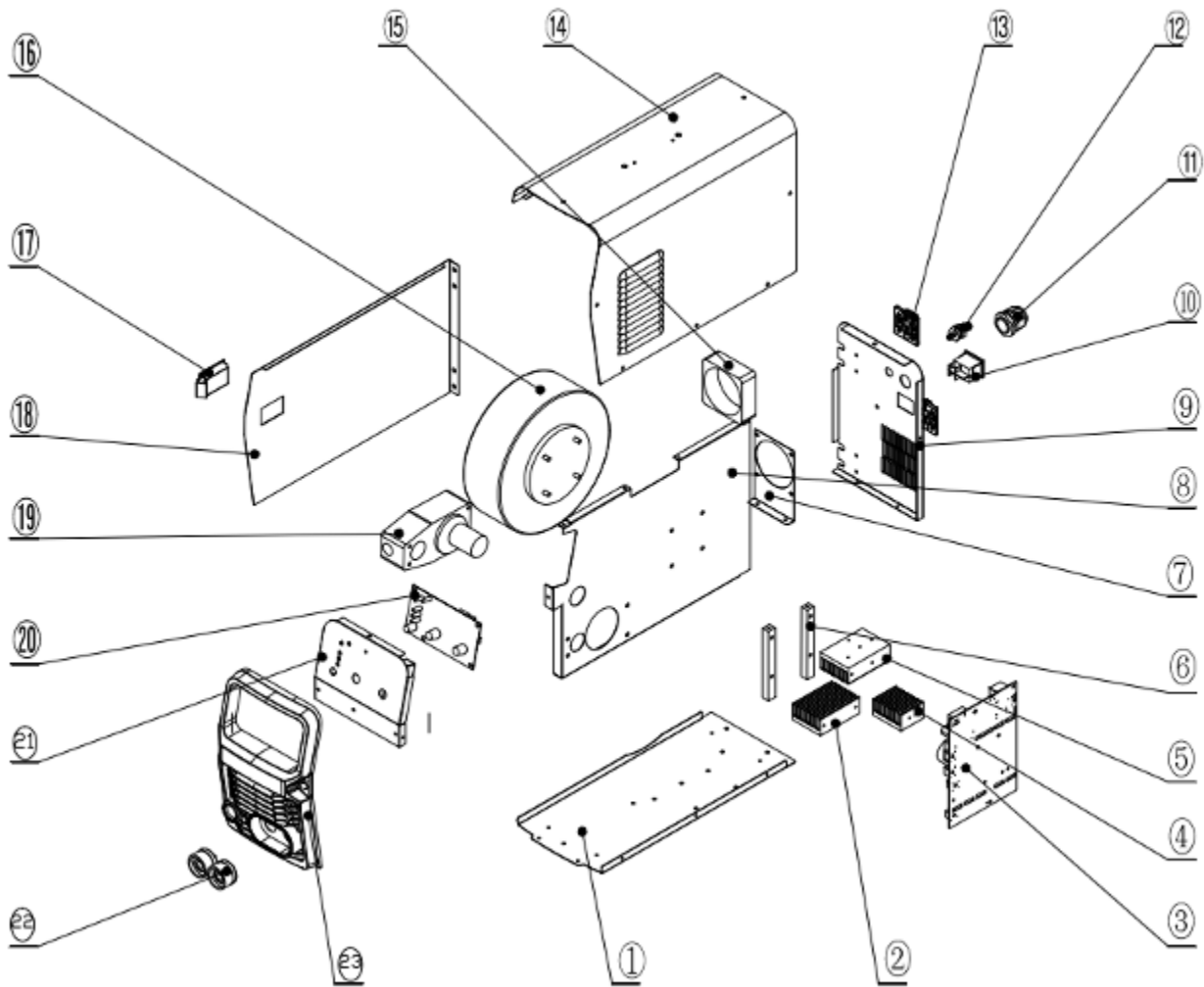

1	Base plate	13	Hinge
2	Rectifier radiator	14	Machine cover
3	Main board	15	Fan
4	IGBT radiator(up)	16	MIG wire spool shaft
5	IGBT radiator(down)	17	Lock
6	Fixed beam	18	Side plate
7	Fan support	19	MIG wire feeder
8	Clapboard	20	Control board
9	Rear panel	21	Front panel
10	Power switch	22	Quick connector
11	Wire buckle	23	Front plastic panel
12	Welding gas inlet		

## **14.IGBT Equipment Warranty**

**Welding Material Sales  
Effective Jan 1, 2019**

### **Limited Warranty**

This warranty applies to the original purchaser and is subject to the terms and conditions listed below.

This Limited Warranty is for new equipment sold after the above date, providing coverage for defects in material and workmanship at the time it is shipped from the factory.

Limited to the warranty periods listed below, Welding Material Sales will repair or replace the item under warranty that fails due to defects in material and workmanship. Welding Material Sales, Inc. must be notified within 30 days of the failure, so as to provide instructions on how to proceed with the repair of your welder and warranty claim processing. Warranty period begins at the time the welder is purchased from an authorized Welding Material Sales, Inc. distributor and/or retailer. Proof of purchase will be required for Welding Material Sales to proceed with any and all warranty claims, no exceptions.

### **Warranty Periods**

Limited Warranty is divided into two categories: No warranty and 1 year.

#### **No Warranty**

Normal wear items including but not limited to MIG gun parts (contact tips, nozzle, adapter, liner), TIG torch parts (collet, cup, back cap, torch body) drive roll, contactor, and electrode holder are not covered under warranty.

#### **1 Year**

Solenoid valve, PC board, controls, gas valve, drive motor, and drive system. Parts and labor performed by authorized repair center with original equipment repair parts. Call 888-905-6737 for a repair center near you.

**Blue Demon Welding Products**

**Geneva, Illinois 60134**

**888-905-6737**

**[www.bluedemonwelding.com](http://www.bluedemonwelding.com)**